

3-phase Hybrids-FAQ

Replacement or expansion of residential energy storage battery module

Applicable to: SBR HV Batteries

Scenario:

1. If the customer needs to add more battery modules (for example, add two battery modules to an existing SBR096).
2. If one battery module is faulty and new battery module needs to be replaced.
3. If two battery modules need to be removed.

Solution:

For scenarios 1 and 2, the battery modules in use need to be charged or discharged to SOC of the new battery. New battery's SOC can be estimated with knowing manufacturing date and storage time. (see below table)

Time	Remaining Estimated SOC
< 3month	24.0 %
3 ~ 4 month	23.0 %
4 ~ 5 month	22.0 %
5 ~ 6 month	21.0 %
6 ~ 7 month	20.5 %
7 ~ 8 month	20.0 %
8 ~ 9 month	19.5 %

EM	46	A	1	20	3	04	0001	A	A
				Year	Month	Day			



Assume for example that the SOC of the new battery module is 20%, and the battery on user site is 70%, please proceed as follows:

Select Compulsory Mode in the Energy Management Parameters, set Charge as a charging command and set Charging/Discharging Power (Parameter 1-2).

Apply the settings.

The screenshot shows the 'Advanced Settings' window with the following table of parameters:

No.	Parameter Name	Latest Value Update Time:2022-04-01 15:45:38	Numerical Term	Degree of accuracy	Unit	Remarks
1	Energy Management Mode	Self-Consumption	Compulsory Mode	--	--	--
1-1	Charging/Discharging Command	Stop	Please Select	--	--	--
1-2	Charging/Discharging Power	0	Please Select	0.01	kW	0~10.6
2	Charging Start Power	0	Charge	0.01	kW	0~5
3	Discharging Start Power	0	Discharge	0.01	kW	0~5
4	External EMS Heartbeat	0	Stop	1	s	1~1000

Set the SOC Upper Limit to 100% and the SOC Lower Limit to 20 % (calculated value for the new battery). Apply the settings. By charging the battery to 100%, a calibration is performed to improve the accuracy of SOC.

(This takes some time, can be omitted and the target SOC value can be directly set and charged or discharged to the target SOC.)

The screenshot shows the 'Advanced Settings' window with the following table of parameters:

No.	Parameter Name	Latest Value Update Time:2022-04-01 15:45:38	Numerical Term	Degree of accuracy	Unit	Remarks
1	SOC Upper Limit	100	100	0.1	%	50~100
2	SOC Lower Limit	10	20	0.1	%	0~50
3	Protection Value of Battery Average Overvoltage	0		0.1	V	0~1000
4	Max. Charging Power	3.2		0.01	kW	0.01~10.6
5	Max. Discharging Power	4.5		0.01	kW	0.01~10.6
6	Battery Capacity(kWh)	0		0.01	kWh	0~600

After charging to 100%, select discharge, set Charging/Discharging Power (Parameter 1-2) and apply the settings. The battery will automatically discharge to 20% and stop.

The screenshot shows the 'Advanced Settings' window with the 'Energy Management Parameters' tab selected. The table below contains the following data:

No.	Parameter Name	Latest Value Update Time:2022-04-01 15:45:38	Numerical Term	Degree of accuracy	Unit	Remarks
1	Energy Management Mode	Self-Consumption	Compulsory Mode	--	--	--
1-1	Charging/Discharging Command	Stop	Please Select	--	--	--
1-2	Charging/Discharging Power	0	Please Select	0.01	kW	0~10.6
2	Charging Start Power	0	Charge	0.01	kW	0~5
3	Discharging Start Power	0	Discharge	0.01	kW	0~5
4	External EMS Heartbeat	0	Stop	1	s	1~1000

Now the battery SOC on user site is the same as SOC of the new battery module 20%, so the installer can install the new battery module.

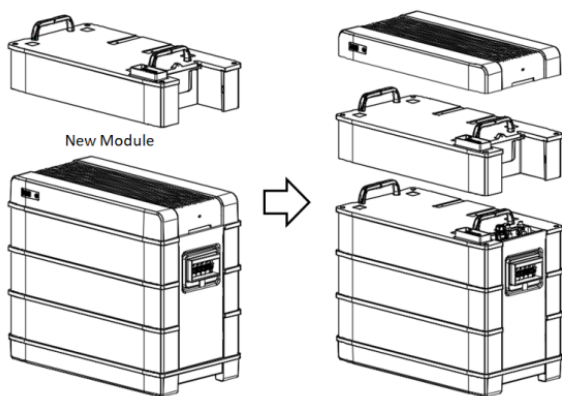

After replacement, stop Compulsory mode and reset Upper and Lower SOC Limit to its original values. (default: SOC upper limit 100%, SOC lower limit 10%)

For scenario 3, we can remove two modules directly, because the power of the five modules is the same. If we remove two battery modules, the remaining three battery modules will also work normally.

For further information, please download the user manual [here](#).

This manual is intended for professional technicians who are responsible for installation, operation, maintenance and troubleshooting of inverters, and users who need to check inverter parameters. The inverter must only be installed by professional technicians.

The professional technician is required to meet the following requirements:

- Know electronic, electrical wiring and mechanical expertise, and be familiar with electrical and mechanical schematics.
- Have received professional training related to the installation, commissioning and troubleshooting of electrical equipment.
- Be able to quickly respond to hazards or emergencies that occur during installation, commissioning and troubleshooting.
- Be familiar with local standards and relevant safety regulations of electrical systems.
- Read this manual thoroughly and understand the safety instructions related to operations.